

FCC Information and Copyright

This equipment has been tested and found to comply with the limits for a Class A digital device, pursuant to part 15 of the FCC Rules. These limits are designed to provide reasonable protection against harmful interference when the equipment is operated in a commercial environment. This equipment generates, uses, and can radiate radio frequency energy and, if not installed and used in accordance with the instruction manual, may cause harmful interference to radio communications. Operation of this equipment in a residential area is likely to cause harmful interference in which case the user will be required to correct the interference at his own expense.

The vendor makes no representations or warranties with respect to the contents here and specially disclaims any implied warranties of merchantability or fitness for any purpose. Further the vendor reserves the right to revise this publication and to make changes to the contents here without obligation to notify any party beforehand.

Duplication of this publication, in part or in whole, is not allowed without first obtaining the vendor's approval in writing.

The content of this user's manual is subject to be changed without notice and we will not be responsible for any mistakes found in this user's manual. All the brand and product names are trademarks of their respective companies.



Dichiarazione di conformità sintetica

Ai sensi dell'art. 2 comma 3 del D.M. 275 del 30/10/2002

Si dichiara che questo prodotto è conforme alle normative vigenti e soddisfa i requisiti essenziali richiesti dalle direttive 2004/108/CE, 2006/95/CE e 1999/05/CE quando ad esso applicabili

Short Declaration of conformity

We declare this product is complying with the laws in force and meeting all the essential requirements as specified by the directives 2004/108/CE, 2006/95/CE and 1999/05/CE whenever these laws may be applied

Table Of Contents

FCC Information and Copyright	1
Chapter 1: Introduction.....	3
1.1 Before You Start	3
1.2 Specifications	4
1.3 Rear Panel Connectors	5
1.4 Motherboard Layout.....	6
Chapter 2: Hardware installation.....	8
2.1 Central Processing Unit (CPU).....	8
2.2 Fan Headers	8
2.3 Expansion Slot.....	8
2.4 Jumpers / Slot / Headers / Connectors	9
Chapter 3: BIOS Setup.....	16
3.1 Main Menu	17
3.2 Advanced Menu.....	18
3.3 Chipset Menu.....	30
3.4 Security Menu.....	35
3.5 Boot Menu	37
3.6 Exit Menu	38

Chapter 1: Introduction

1.1 Before You Start

Thank you for choosing our product. Before you start installing the motherboard, please make sure you follow the instructions below:

- Prepare a dry and stable working environment with sufficient lighting.
 - Always disconnect the computer from power outlet before operation.
 - Before you take the motherboard out from anti-static bag, ground yourself properly by touching any safely grounded appliance, or use grounded wrist strap to remove the static charge.
 - Avoid touching the components on motherboard or the rear side of the board unless necessary. Hold the board on the edge, do not try to bend or flex the board.
 - Do not leave any unfastened small parts inside the case after installation. Loose parts will cause short circuits which may damage the equipment.
 - Keep the computer from dangerous area, such as heat source, humid air and water.
 - The operating temperatures of the computer should be 0 to 45 degrees Celsius.
 - To avoid injury, be careful of:
 - Sharp pins on headers and connectors
 - Rough edges and sharp corners on the chassis
 - Damage to wires that could cause a short circuit
-

Note

- » *The package contents may be different due to the sales region or models in which it was sold. For more information about the standard package in your region, please contact your dealer or sales representative.*
-

1.2 Specifications

CPU	Intel® Braswell SoC N3160 (QC-2.24GHz) / Micro-FCBGA (SoC-type) Maximum CPU TDP (Thermal Design Power): 6Watt
Graphic	Within Intel Braswell SoC Dual independent displays (Extended mode) as below: -- HDMI Port (Max resolution 1920 x 1200) -- VGA Port (Max resolution 1920 x 1200) -- LVDS 18/24-bit Dual channel (Max resolution 1920 x 1200)
Main Memory	Intel Braswell SoC, Single Channel 4GB Supports Non-ECC DDR3L Memory running at 1600MHz Max. Supports up to 4GB Memory
Storage	Intel® Braswell SoC Onboard 32GB or 64GB Flash (depends on PCB space) 2x SATA 3.0 Connector (1x SATA Connector for HDD / SSD, 1x Mini-PCIe Connector for mSATA), AHCI mode support
Expansion Slot	Intel Braswell SoC 1x Mini-PCIe (with USB 2.0 & PCIe interface), only support full-size type
LAN1 / 2	Intel I211-AT GbE 10 / 100 / 1000 Mb/s auto negotiation, Half / Full duplex capability
Sound Codec	Realtek Codec ALC662, supports Line-out / Mic-in High Definition Audio
Rear Panel I/O	1x HDMI Port 1x VGA Port 2x Dual USB 3.0 Port 2x RJ-45 Gigabit LAN (LAN1 / LAN2)
Internal I/O (On Board Connectors)	1x Onboard DDR3L 4GB Memory 1x 2*15 Wafer Box Pin-Header for LVDS Connector 1x 1*6 Pins, 2.0-Pitch Connector 1x 1*3 Pins, 2.0-Pitch Wafer Box Pin-Header for 5V/12V Select 1x 2*4 Pins, 2.0-Pitch Wafer Box Pin-Header for front LAN LED 1x SATA 3.0 Connector 1x 1*4 Pins, Power Connector for HDD (Support 5V and 12V) 1x mSATA Connector 2x 2*5 Pins, 2.0-Pitch Wafer Box Pin-Header 1x 2*10 Pins, 2.0-Pitch Wafer Box Pin-Header 1x Mini-PCIe Connector with USB 2.0 & PCIe 1X Interface (Mini-PCIe only support full-size with SIM Holder) 1x 1*4 Pins, 2.0-Pitch Wafer Box Pin-Header for 2x 2W Amplifier 1x 1*3 Pins, Pin-Header for Select PS/2 Power 5V/5VSB 1x 1*6 Pins, SIM-Holder Connector for SIM-Card 1x 1*3 Pins, 2.0-Pitch Pin-Header for Select AT/ATX Mode 1x 1*3 Clear CMOS Header / 2.0-Pitch 6x 2*5 Pins, 2.0-Pitch Wafer Box Pin-Header for COM1~COM6 1x 1*3 Pins, 2.0-Pitch Wafer Box Pin-Header 1x 2*5 Pins, 2.0-Pitch Wafer Box Pin-Header (4*GPI, 4*GPO) 1x 1*3 Pins, Pin-Header for Select Rear USB3.0 Power 1x 2*5 pins, 2.0-Pitch Wafer Box Pin-Header for Line-out/MIC/Line-in 1x 2*5 Pins, 2.0-Pitch Wafer Box Pin-Header 1x 1*3 Pins, Wafer Connector Smart DC FAN for System 1x 2*4 pins, SPI Flash Socket Connector 1x 1*2 pins, 1.0-Pitch Connector for Battery (Cable-Type) 1x 1*2 pins, VGAL Header 1x Buzzer 2x Stanyby LED 1x Power LED for Motherboard Power-on Display 1x 1*2 Pins Phoenix-Type Power Connector for DC-in 9~24V
Board Size	102 mm (W) x 148 mm (L), 3.5" SBC
Operation Temperature	0°C ~ 60°C
Storage Temperature	-20°C ~ 80°C
Relative Humidity	10% ~ 90% (non-condensing)
Qualification	CE / FCC Class A
Green /APM	ACPI 2.0S0/S1/S5, Support AC Power auto power on by BIOS select
OS Driver Support	Windows 7 (32/64bit) / Windows 8.1 (64bit) / Windows 10 (32bit), Ubuntu 16.04
roHS Compliant	Yes

1.3 Rear Panel Connectors

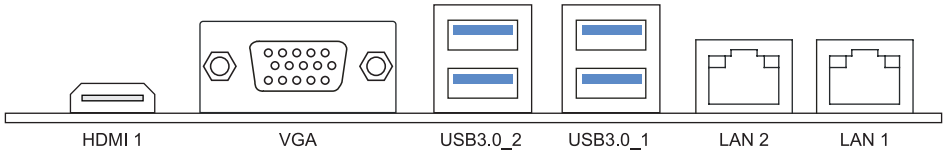

1.4 Motherboard Layout

Top View

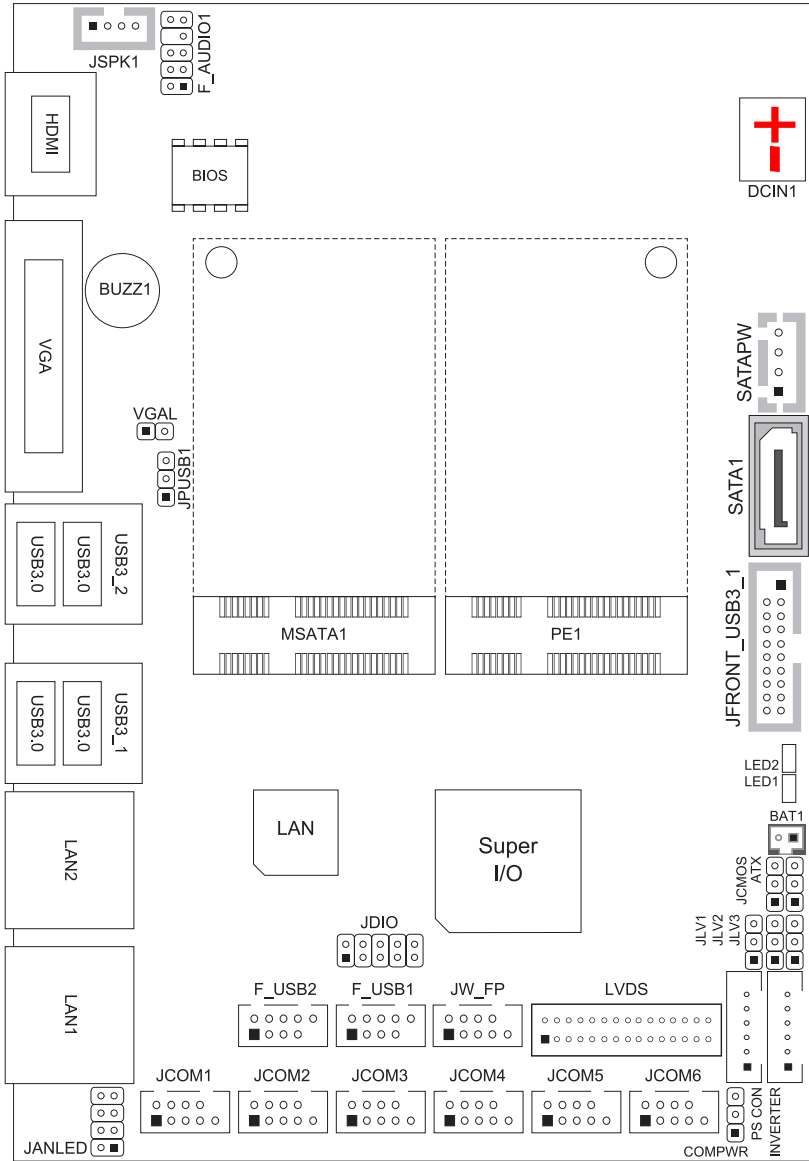

Back View

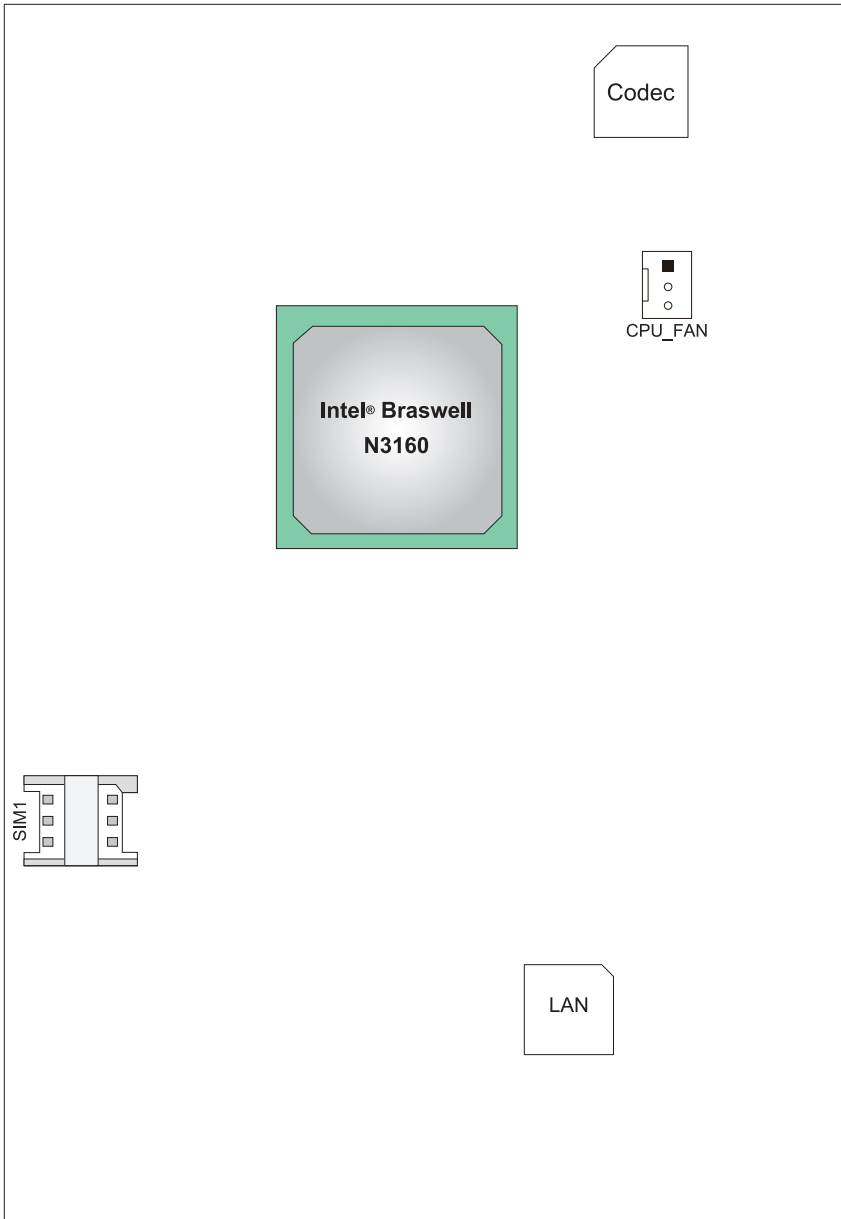

» ■ represents the 1st pin.

Chapter 2: Hardware installation

2.1 Central Processing Unit (CPU)

The mainboard includes an Intel® Celeron processor, and a cooler has been installed to provide sufficient cooling

2.2 Fan Headers

These fan headers support cooling-fans built in the computer. The fan cable and connector may be different according to the fan manufacturer. Connect the fan cable to the connector while matching the black wire to pin#1.

CPU_FAN1: CPU Fan Header

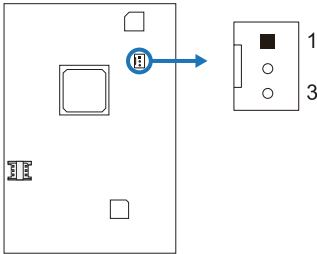

Pin	Assignment
1	Ground
2	Smart Fan Control (By Fan)
3	FAN RPM rate sense

2.3 Expansion Slot

Installing WiFi Module

1. Insert WiFi module into mini PCIe slot (PE1)
2. Secure screw to the motherboard

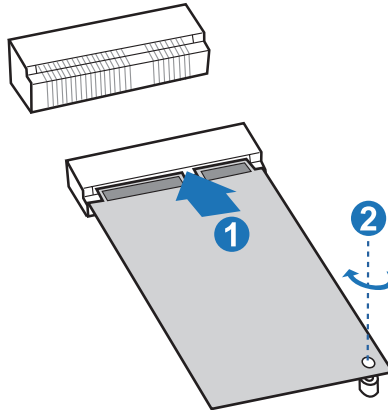

» *Wi-Fi module & screw sold separately.*

Installing mSATA Module

1. Insert mSATA module into mini PCIe slot (MSATA1)
2. Secure screw to the motherboard

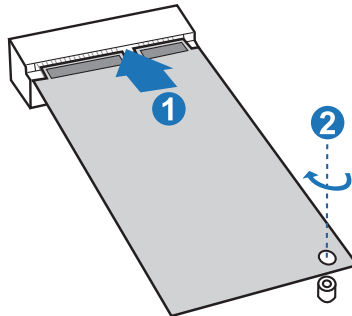

» mSATA module & screw sold separately.

2.4 Jumpers / Slot / Headers / Connectors

Jumper Setting

The illustration shows how to set up jumpers. When the jumper cap is placed on pins, the jumper is “close”, if not, that means the jumper is “open”.

Pin opened



Pin closed



Pin 1-2 closed



JCMOS1: Clear CMOS Jumper

Placing the jumper on pin2-3 allows user to restore the BIOS safe setting and the CMOS data. Please carefully follow the procedures to avoid damaging the motherboard.

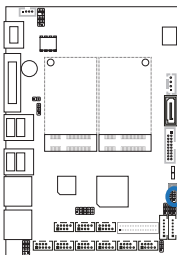

Pin 1-2 Close: Normal Operation (Default)



Pin 2-3 Close: Clear CMOS data

Clear CMOS Procedures:

1. Remove AC power line.
2. Set the jumper to “Pin 2-3 close”.
3. Wait for five seconds.
4. Set the jumper to “Pin 1-2 close”.
5. Power on the AC.
6. Reset your desired password or clear the CMOS data.

PS2_CON: PS/2 Keyboard & Mouse Connector

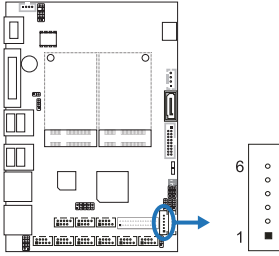

Pin	Assignment
1	MS_CLK
2	PS2_VCC
3	KB_CLK
4	MS_DATA
5	SP2_GND
6	KB_DATA

SATA1: Serial ATA Connector

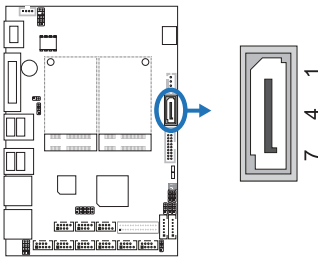

Pin	Assignment
1	Ground
2	TX+
3	TX-
4	Ground
5	RX-
6	RX+
7	Ground

SATAPW: SATA Hard Disk Power-out Connector

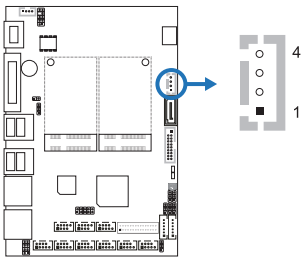

Pin	Assignment
1	+5V
2	Ground
3	Ground
4	+12V

F_USB1/2: USB 2.0 Connectors

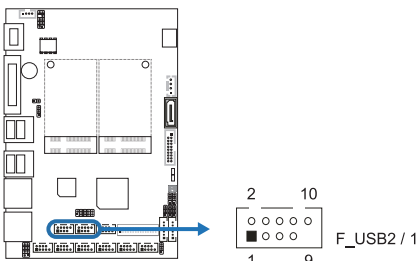

F_USB2		F_USB1	
Pin	Assignment	Pin	Assignment
1	VCC	1	VCC
2	NC	2	VCC
3	D-	3	DATA-
4	NC	4	DATA-
5	D+	5	DATA+
6	NC	6	DATA+
7	GND	7	GND
8	NC	8	GND
9	NC	9	N/A
10	NC	10	NC

JW_FP: Front Panel Header

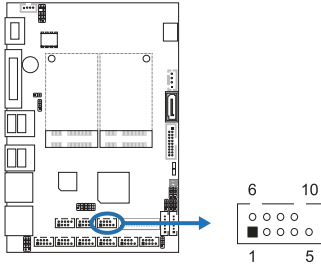

Pin	Assignment	Function
1	HDD LED+	HDD LED
2	HDD LED-	
3	GND	Reset Button
4	Reset Switch	
5	VCC5	N/A
6	Power LED+	Power LED
7	Power LED-	
8	Power Button	Power Button
9	GND	
10	N/A	N/A

JDIO: Digital I/O Connector

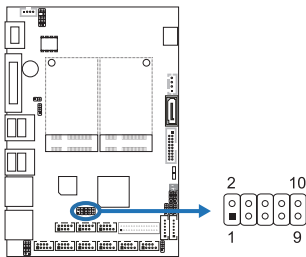

Pin	Function	Assignment	Address	Read
1	Output	DO-01	0xFED8D058	BIT1
2	Input	DI-01	0xFED8D018	BIT0
3	Output	DO-02	0xFED8D000	BIT1
4	Input	DI-02	0xFED8D040	BIT0
5	Output	DO-03	0xFED8D020	BIT1
6	Input	DI-03	0xFED8D008	BIT0
7	Output	DO-04	0xFED8D048	BIT1
8	Input	DI-04	0xFED8D030	BIT0
9	--	GND	--	--
10	--	5V	--	--

JSPK1: Speaker Header

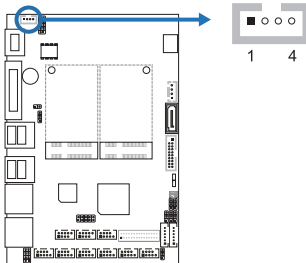

Pin	Assignment
1	L-
2	L+
3	R+
4	R-

F_AUDIO: Front Panel Audio Header

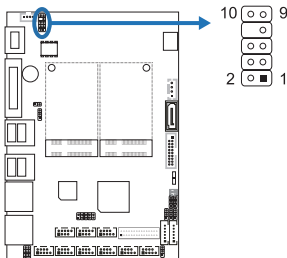

Pin	Assignment	Pin	Assignment
1	MIC2-L	2	GND
3	MIC2-R	4	N/A
5	LINE_OUT-R	6	N/A
7	N/A	8	N/A
9	LINE_OUT-L	10	N/A

JANLED: Front LAN LED Connector

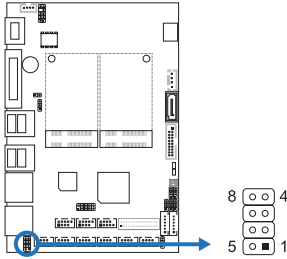

Pin	Assignment
1	LAN1_VCC
2	LAN1_100M
3	LAN2_VCC
4	LAN2_100M
5	LAN1_ACT
6	LAN1_1G
7	LAN2_ACT
8	LAN2_1G

INVERTER: LCD Backlight Inverter Connector

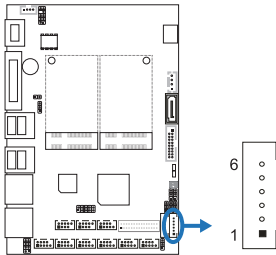

Pin	Assignment
1	BKLT_PWR
2	BKLT_PWR
3	BKLT_EN
4	BKLT_PWM
5	GND
6	GND

LVDS: 24-bit Dual Channel LVDS Connector

This connector supports 18/24 bit Dual-channel panels.

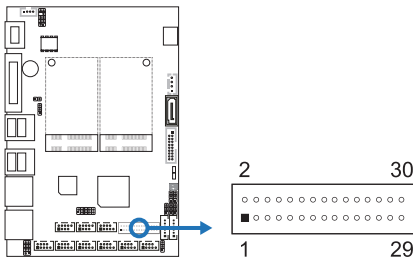

Pin	Assignment	Pin	Assignment
1	LVDSB_DATAN3	2	LVDSB_DATAP3
3	LVDS_CLKBN	4	LVDS_CLKBP
5	LVDSB_DATAN2	6	LVDS_DATAP2
7	LVDSB_DATAN1	8	LVDS_DATAP1
9	LVDSB_DATAN0	10	LVDS_DATAP0
11	NC/DDC_DATA	12	NC/DDC_CLK
13	GND	14	GND
15	GND	16	GND
17	LVDSA_DATAP3	18	LVDSA_DATAN3
19	LVDS_CLKAP	20	LVDS_CLKAN
21	LVDSA_DATAP2	22	LVDSA_DATAN2
23	LVDSA_DATAP1	24	LVDSA_DATAN1
25	LVDSA_DATAP0	26	LVDSA_DATAN0
27	PVCC	28	PVCC
29	PVCC	30	PVCC

JCOM1/2/3/4/5/6: Serial Port Connectors

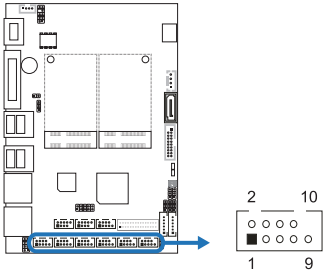

Pin	RS-232	RS-422 (for COM1)	RS-485 (for COM1)
1	Carrier detect (DCD)	TX-	DATA-
2	Received data (RXD)	TX+	DATA+
3	Transmitted data (TXD)	RX+	NC
4	Data terminal ready (DTR)	RX-	NC
5	Signal ground (GND)	GND	GND
6	Data set ready (DSR)	NC	NC
7	Request to send (RTS)	NC	NC
8	Clear to send (CTS)	NC	NC
9	Ring	NC	NC
10	N/A	N/A	N/A

JPU5B1: Power Source Jumpers for USB Ports

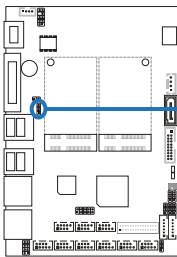

Pin 1-2 Close: VCC5S (5V)



Pin 2-3 Close: VCC5A (Standby)

VGAL: VGAL Header

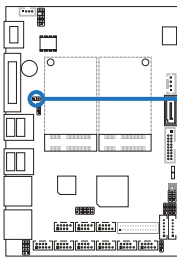

Pin 1-2: Open



Pin 1-2 Close: Short (Default)

JLV1: LCD Power Select Header (3.3V/5V)

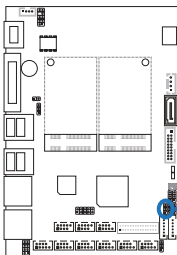

Pin 1-2 Close: VCC5S (5V)



Pin 2-3 Close: 3.3V

JLV2: LCD Backlight Inverter Power Select Header (5V/12V)

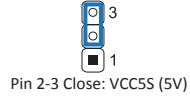
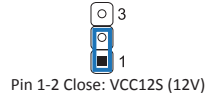
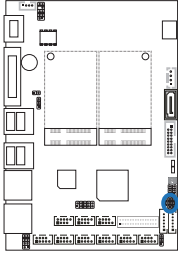

JLV3: LCD PWM / Voltage Level Mode Select Header

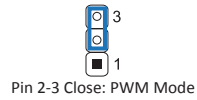
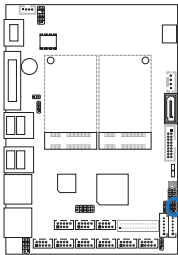

COMPWR: Serial Port Power Select Jumper

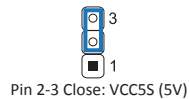
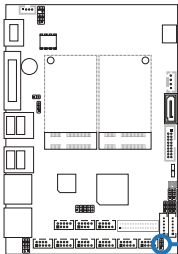

ATX: AT/ATX Power Switch Header

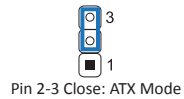
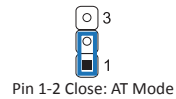
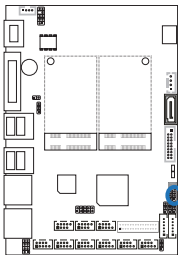

MSATA1: mSATA Connector

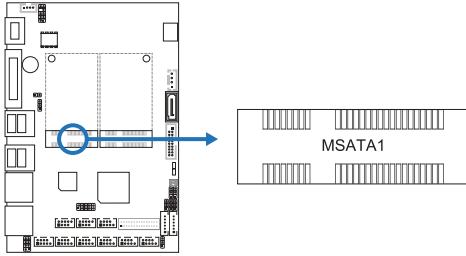

PE1: Mini PCIe Connector

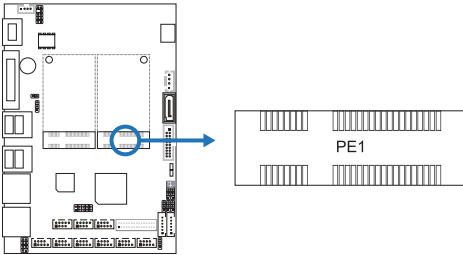

SIM1: NANO SIM Card Socket

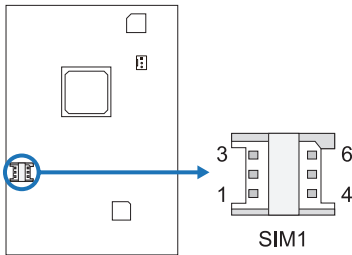

Pin	Assignment	Pin	Assignment
1	VCC	4	GND
2	RST	5	VPP
3	CLK	6	DATA

LED1/2: Power LED

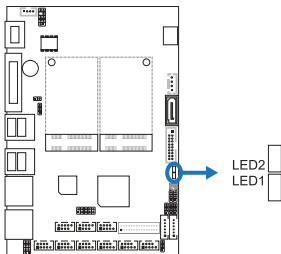

LED No.	Function	LED Color
LED1	Standby	Red
LED2	Power On	Blue

Chapter 3: BIOS Setup

Introduction

The purpose of this manual is to describe the settings in the AMI UEFI BIOS Setup program on this motherboard. The Setup program allows users to modify the basic system configuration and save these settings to NVRAM.

UEFI BIOS determines what a computer can do without accessing programs from a disk. This system controls most of the input and output devices such as keyboard, mouse, serial ports and disk drives. BIOS activates at the first stage of the booting process, loading and executing the operating system. Some additional features, such as virus and password protection or chipset fine-tuning options are also included in UEFI BIOS.

The rest of this manual will to guide you through the options and settings in UEFI BIOS Setup.

Plug and Play Support

This AMI UEFI BIOS supports the Plug and Play Version 1.0A specification.

EPA Green PC Support

This AMI UEFI BIOS supports Version 1.03 of the EPA Green PC specification.

ACPI Support

AMI ACPI UEFI BIOS support Version 1.0/2.0 of Advanced Configuration and Power interface specification (ACPI). It provides ASL code for power management and device configuration capabilities as defined in the ACPI specification, developed by Microsoft, Intel and Toshiba.

PCI Bus Support

This AMI UEFI BIOS also supports Version 2.3 of the Intel PCI (Peripheral Component Interconnect) local bus specification.

DRAM Support

DDR3 SDRAM (Double Data Rate III Synchronous DRAM) is supported.

Supported CPUs

This AMI UEFI BIOS supports the latest CPU.

Using Setup

When starting up the computer, press during the Power-On Self-Test (POST) to enter the UEFI BIOS setup utility. In the UEFI BIOS setup utility, you will see General Help description at the top right corner, and this is providing a brief description of the selected item. Navigation Keys for that particular menu are at the bottom right corner, and you can use these keys to select item and change the settings.

Note

- » *The default UEFI BIOS settings apply for most conditions to ensure optimum performance of the motherboard. If the system becomes unstable after changing any settings, please load the default settings to ensure system's compatibility and stability. Use Load Setup Default under the Exit Menu.*
 - » *For better system performance, the UEFI BIOS firmware is being continuously updated. The UEFI BIOS information described in this manual is for your reference only. The actual UEFI BIOS information and settings on board may be slightly different from this manual.*
 - » *The content of this manual is subject to be changed without notice. We will not be responsible for any mistakes found in this user's manual and any system damage that may be caused by wrong-settings.*
-

3.1 Main Menu

Once you enter AMI UEFI BIOS Setup Utility, the Main Menu will appear on the screen providing an overview of the basic system information.

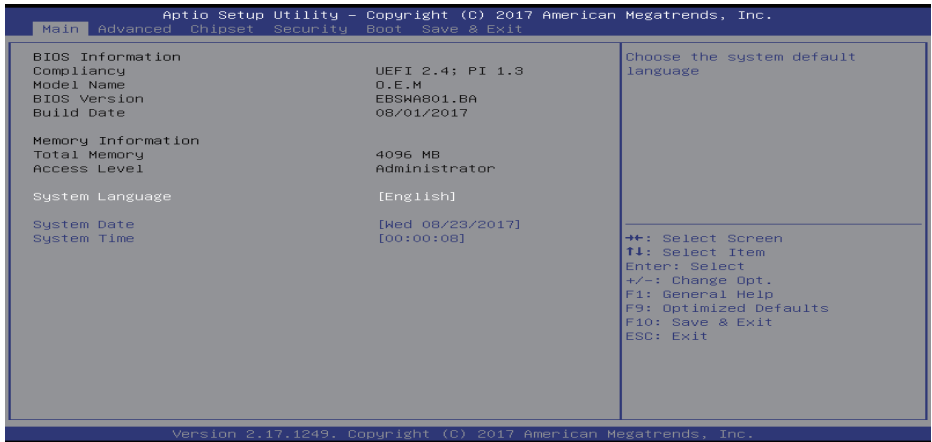

BIOS Information

Shows system information including UEFI BIOS version, model name, marketing name, built date, etc.

Total Memory

Shows system memory size, VGA shard memory will be excluded.

Access Level

Shows the access level of current user.

System Language

Choose the system default language.

System Date

Set the system date. Note that the 'Day' automatically changes when you set the date.

System Time

Set the system internal clock.

3.2 Advanced Menu

The Advanced Menu allows you to configure the settings of CPU, Super I/O, Power Management, and other system devices.

Note

- » Beware of that setting inappropriate values in items of this menu may cause system to malfunction.
- » The options and default settings might be different by RAM or CPU models.



ACPI Settings

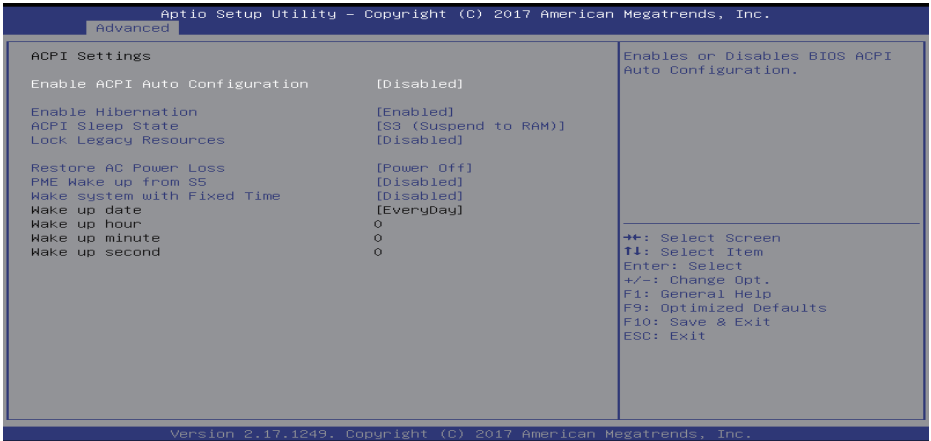

Enable ACPI Auto Configuration

This item enables or disables BIOS ACPI Auto Configuration.

Options: Disabled (Default) / Enabled

Enable Hibernation

This item enables or disables system ability to hibernate (OS/S4 sleep state). This option may be not effective with some OS.

Options: Enabled (Default) / Disabled

ACPI Sleep State

This item selects the highest ACPI sleep state the system will enter when the SUSPEND button is pressed.

Options: S3 (Suspend to RAM)(Default) / Suspend Disabled

Lock Legacy Resources

This item enables or disables Lock of Legacy Resources.

Options: Disabled (Default) / Enabled

Restore AC Power Loss

This item specify what state to go to when power is re-applied after a power failure.

Options: Power Off (Default) / Power On / Last State

PME Wake up from S5

This item enables the system to wake from S5 using PME event.

Options: Disabled (Default) / Enabled

Wake system with Fixed Time

This item enables or disables the system to wake on by alarm event. When this item is enabled, the system will wake on the hr::min::sec specified.

Options: Disabled (Default) / Enabled

Wake up date

You can choose which date the system will boot up.

Wake up hour / Wake up minute / Wake up second

You can choose the system boot up time, input hour, minute and second to specify.

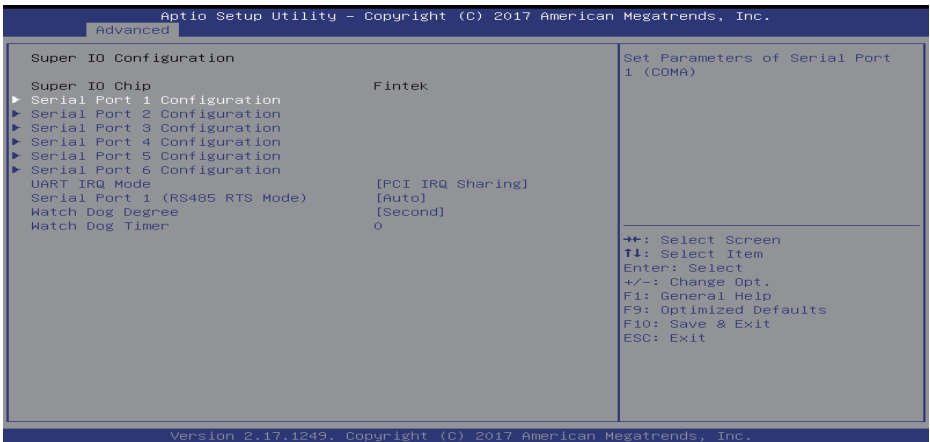
Super IO Configuration

Serial Port 1/2/3/4/5/6 Configuration

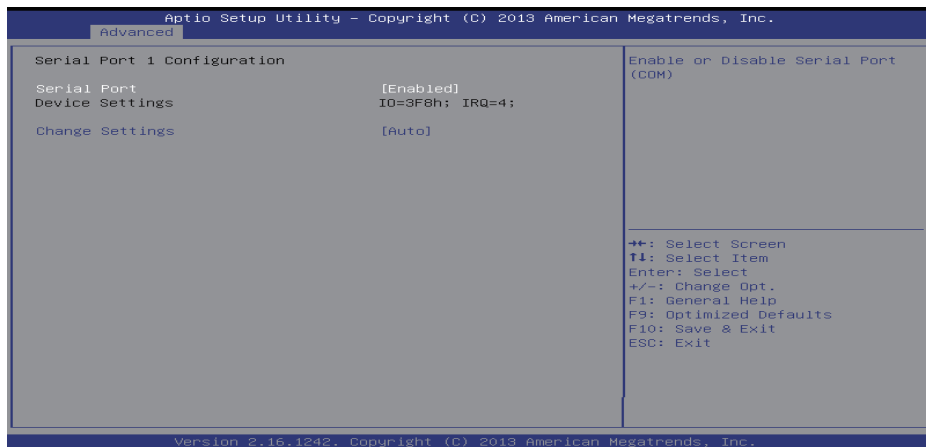

Serial Port

This item enables or disables Serial Port (COM).

Options: Enabled (Default) / Disabled

Change Settings

This item selects an optimal setting for Super IO device.

Options: Auto (Default) / IO=3F8h; IRQ=4 / IO=3F8h; IRQ= 3,4,5,6,7,9,10,11,12 / IO=2F8h; IRQ= 3,4,5,6,7,9,10,11,12 / IO=3E8h; IRQ= 3,4,5,6,7,9,10,11,12 / IO=2E8h; IRQ= 3,4,5,6,7,9,10,11,12

COM Port Type (only for Serial Port 1 Configuration menu)

This item allows you to select COM Port type.

Options: RS232 (Default) / RS485 / RS422

Device Mode (only for Serial Port 6 Configuration menu)

This item enable or disable Serial Port (COM).

Options: Disable IR1 function (Default) / Enable IR1 function, active pulse 1.6uS / Enable IR1 function, active pulse 3/16 bit time.

UART IRQ Mode

This item PCI IRQ Sharing for OS (EX.Windows) ISA IRQ for Dos.

Options: PCI IRQ Sharing (Default) / ISA IRQ

Serial Port 1 (RS485 RTS Mode)

If UART set RS485 mode, set enabled RTS will auto control reciver data.

Options: Auto (Default) / Normal

Watch Dog Degree

This item allows you to determine the functional degree of Watch Dog.

Options: Second (Default) / Minute

Watch Dog Timer

Options: 0 for disabled (Default) / Min=1, Max=65535

H/W Monitor

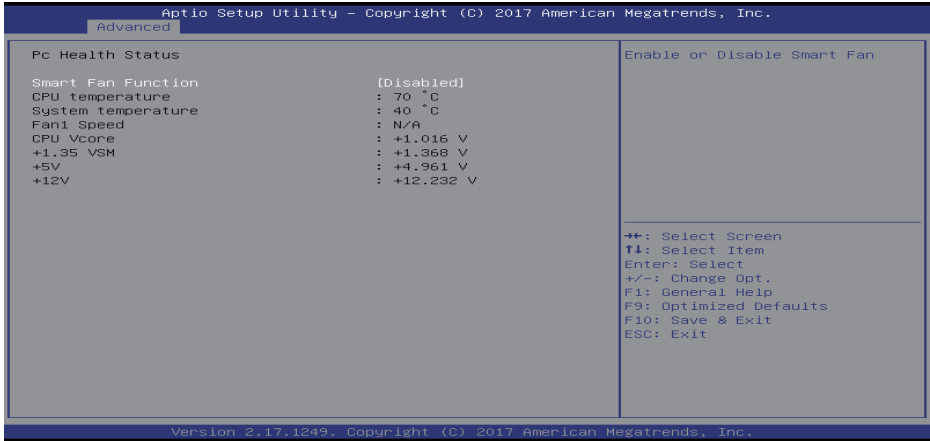

Smart Fan Function

This item enable or disable Smart Fan.

Options: Disabled (Default) / Enabled

» The following items appear only when you set the Smart Fan function to [Enabled].

Smart Fan Mode Configuration

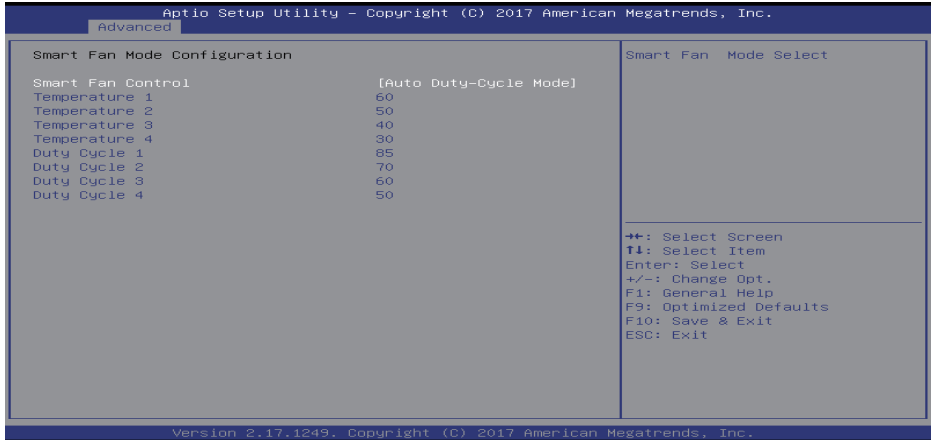

Smart Fan Control

This item allows you to select Smart Fan Mode.

Options: Auto Duty-Cycle Mode (Default) / Manual RPM Mode / Manual Duty Mode / Auto RPM Mode

» The following items appear only when you set the Smart Fan Control function to [Auto Duty-Cycle Mode].

Temperature 1/2/3/4

This item auto fan speed control. Fan speed will follow different temperature by different duty cycle 1-100.

Duty Cycle 1/2/3/4

This item auto fan speed control. Fan speed will follow different temperature by different duty cycle 1-100.

- » The following items appear only when you set the Smart Fan Control function to [Manual RPM Mode].

Temperature 1/2/3/4

This item auto fan speed control. Fan speed will follow different temperature by different duty cycle 1-100.

Full Speed RPM

This item allows you to set fan full speed RPM.

RPM Percentage 1/2/3/4

This item auto fan speed control. Fan speed will follow different temperature by different RPM 1-100.

- » The following items appear only when you set the Smart Fan Control function to [Manual Duty Mode].

Manual Duty Mode

This item Manual mode fan control, user can write expected duty cycle (PWM fan type) 1-100.

- » The following items appear only when you set the Smart Fan Control function to [Manual RPM Mode].

Manual RPM Mode

This item Manual mode fan control, user can write expected RPM count 500-10000.

CPU Configuration

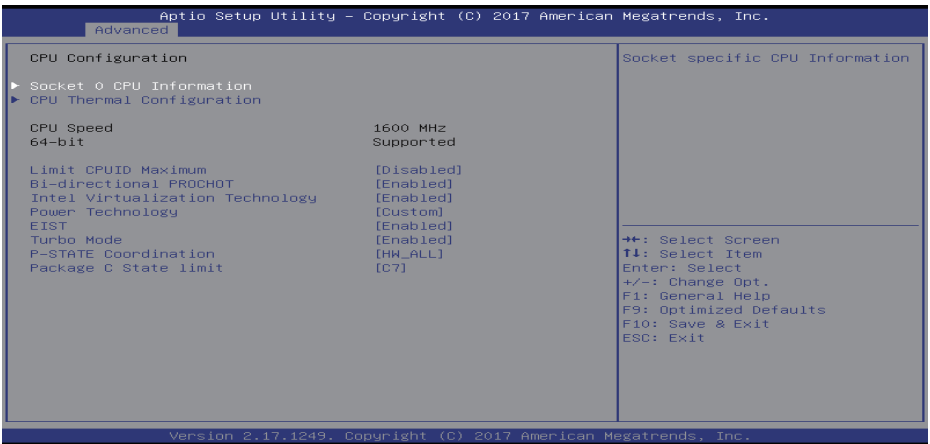

Socket 0 CPU Information

This item shows Socket 0 CPU Information.

CPU Thermal Configuration

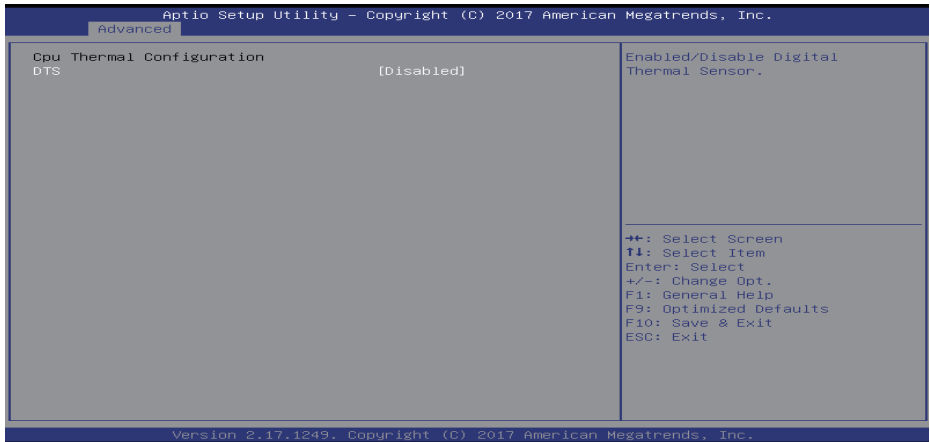

DTS

This item enabled or disabled Digital Thermal Sensor.

Options: Disabled (Default) / Enabled

Limit CPUID Maximum

When the computer is booted up, the operating system executes the CPUID instruction to identify the processor and its capabilities. Before it can do so, it must first query the processor to find out the highest input value CPUID recognizes. This determines the kind of basic information CPUID can provide the operating system.

Options: Disabled (Default) / Enabled

Bi-directional PROCHOT

When a processor thermal sensor trips (either core), the PROCHOT# will be driven. If bi-direction is enabled, external agents can drive PROCHOT# to throttle the processor.

Options: Enabled (Default) / Disabled

Intel Virtualization Technology

Virtualization Technology can virtually separate your system resource into several parts, thus enhance the performance when running virtual machines or multi interface systems. When enabled, a VMM can utilize the additional hardware capabilities provided by Vanderpool Technology.

Options: Enabled (Default) / Disabled

Power Technology

This item enables or disables the power management features.

Options: Custom (Default) / Disable / Energy Efficient

EIST

This item enables or disables Intel SpeedSteps.

Options: Enabled (Default) / Disabled

Turbo Mode

This item enables or disables Turbo Mode.

Options: Enabled (Default) / Disabled

P-STATE Coordination

This item changes P-STATE Coordination.

Options: HW_ALL (Default) / SW_ALL / SW_ANY

Package C state limit

This item enables or disables package C state limit.

Options: C7 (Default) / C1 / C3 / C6

PPM Configuration



EIST

This item enables or disables Intel SpeedSteps.

Options: Enabled (Default) / Disabled

CPU C state Report

This item enables or disables CPU C state report to OS.

Options: Enabled (Default) / Disabled

Max CPU C-state

This option controls Max C state that the processor will support.

Options: C7 (Default) / C6 / C1

SATA Configuration

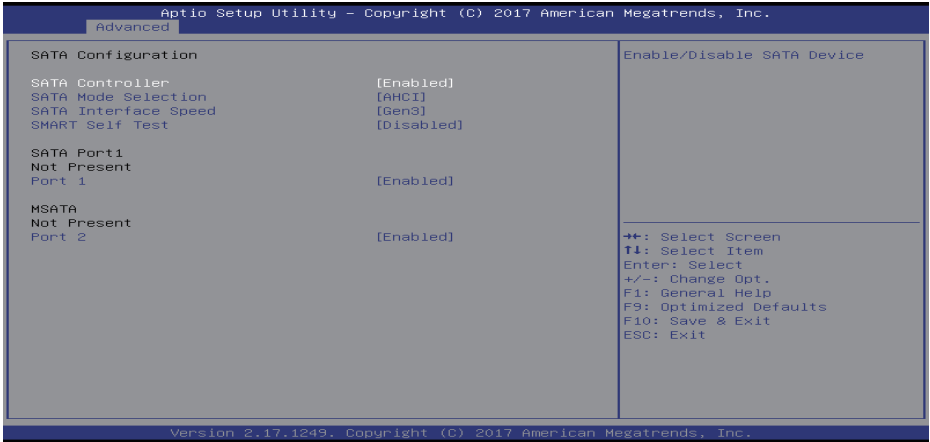

Serial-ATA (SATA)

This item enabled or disabled Serial ATA Device.

Options: Enabled (Default) / Disabled

SATA Mode Selection

This item determines how SATA controller(s) operate.

Options: AHCI (Default)

SATA Interface Speed

This item allows you to select SATA Interface Speed, CHV A1 always with Gen1 Speed.

Options: Gen3 (Default) / Gen2 / Gen1

SMART Self Test

Run SMART Self Test on all HDDs during POST.

Options: Disabled (Default) / Enabled

SATA Port1

This item enabled or disabled SATA port1.

Options: Enabled (Default) / Disabled

MSATA Port2

This item enabled or disabled SATA port2.

Options: Enabled (Default) / Disabled

PCI Subsystem Settings

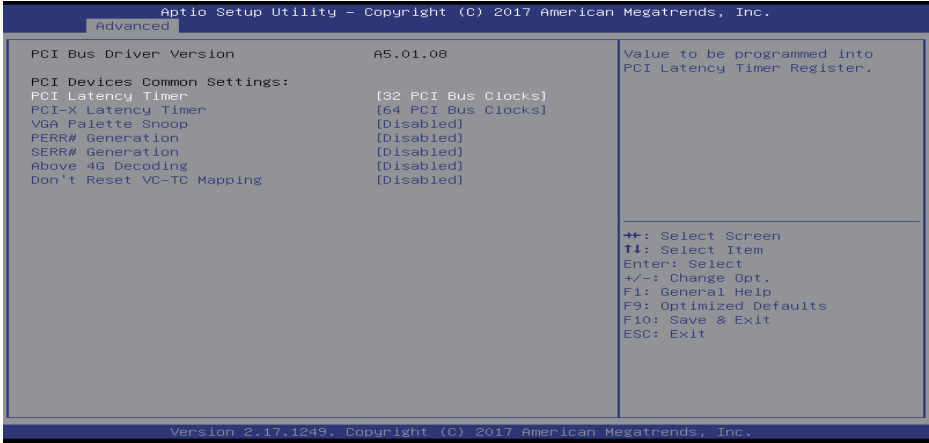

PCI Latency Timer

This item allows you to adjust value to be programmed into PCI Latency Timer Register.

Options: 32 PCI Bus Clocks (Default) / 64 PCI Bus Clocks / 96 PCI Bus Clocks / 128 PCI Bus Clocks / 160 PCI Bus Clocks / 192 PCI Bus Clocks / 224 PCI Bus Clocks / 248 PCI Bus Clocks

PCI-X Latency Timer

This item allows you to adjust value to be programmed into PCI Latency Timer Register.

Options: 64 PCI Bus Clocks (Default) / 32 PCI Bus Clocks / 96 PCI Bus Clocks / 128 PCI Bus Clocks / 160 PCI Bus Clocks / 192 PCI Bus Clocks / 224 PCI Bus Clocks / 248 PCI Bus Clocks

VGA Palette Snoop

This item enabled or disabled VGA Palette Registers Snooping.

Options: Disabled (Default) / Enabled

PERR# Generation

This item enabled or disabled PCI Device to Generate PERR#.

Options: Disabled (Default) / Enabled

SERR# Generation

This item enabled or disabled PCI Device to Generate SERR#.

Options: Disabled (Default) / Enabled

Above 4G Decoding

This item enabled or disabled 64bit capable Devices to be Decoded in Above 4G Address Space (Only if System Supports 64bit PCI Decoding).

Options: Disabled (Default) / Enabled

Don't Reset VC-TC Mapping

If system has Virtual Channels, Software can reset Traffic Class mapping through Virtual Channels, to it's default state. Setting this option to Enabled will not modify VC Resources.

Options: Disabled (Default) / Enabled

Network Stack Configuration

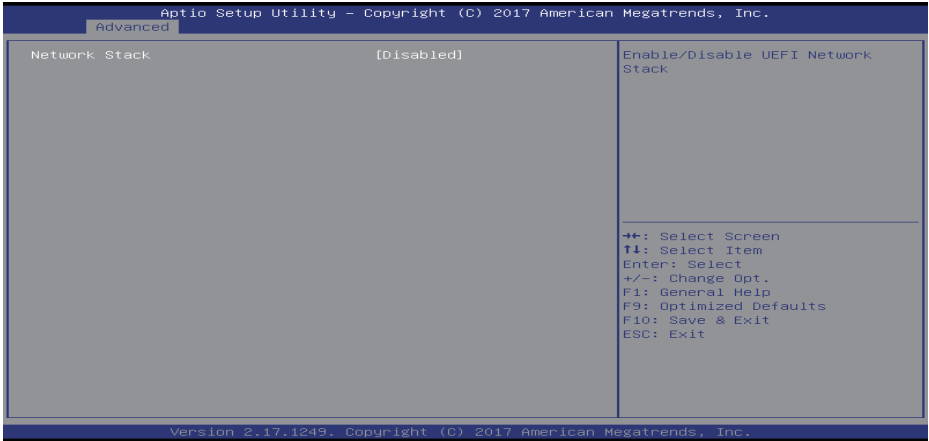

Network Stack

This item enabled or disabled UEFI network stack

Options: Disabled (Default) / Enabled

» *Note: The following items appear only when you set the Network Stack function to [Enabled]*

IPv4 PXE Support

This item enables or disables IPv4 PXE Boot Support. If disabled IPv4 PXE boot option will not be created.

Options: Enabled (Default) / Disabled

IPv6 PXE Support

This item enables or disables IPv6 PXE Boot Support. If disabled IPv6 PXE boot option will not be created.

Options: Enabled (Default) / Disabled

PXE boot wait time

Wait time to press ESC key to abort the PXE boot.

Media detect count

Number of times presence of media will be checked.

CSM Configuration

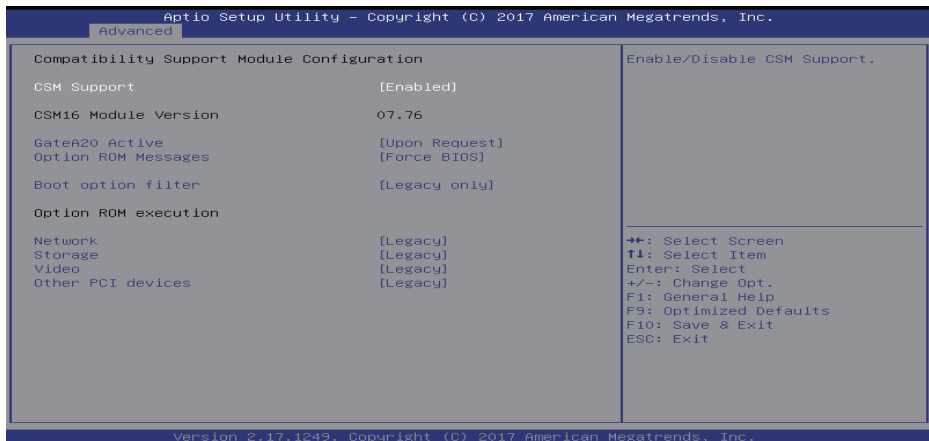

CSM Support

This item enabled or disabled CSM Support

Options: Enabled (Default) / Disabled

GateA20 Active

Upon Request – GA20 can be disabled using BIOS services. Always – do not allow disabling GA20; this option is useful when any RT code is executed above 1MB.

Options: Upon Request (Default) / Always

Option ROM Messages

This item allows you to set display mode for option ROM.

Options: Force BIOS (Default) / Keep Current

Boot option filter

This option controls Legacy and UEFI ROMs priority.

Options: Legacy only (Default) / UEFI and Legacy / UEFI only

Network

This option controls the execution of UEFI and Legacy PXE OpROM.

Options: Legacy (Default) / Do not launch / UEFI

Storage

This option controls the execution of UEFI and Legacy Storage OpROM.

Options: Legacy (Default) / Do not launch / UEFI

Video

This option controls the execution of UEFI and Legacy Video OpROM.

Options: Legacy (Default) / Do not launch / UEFI

Other PCI devices

This item determines OpROM execution policy for devices other than Network, Storage, or Video.

Options: Legacy (Default) / Do not launch / UEFI

USB Configuration

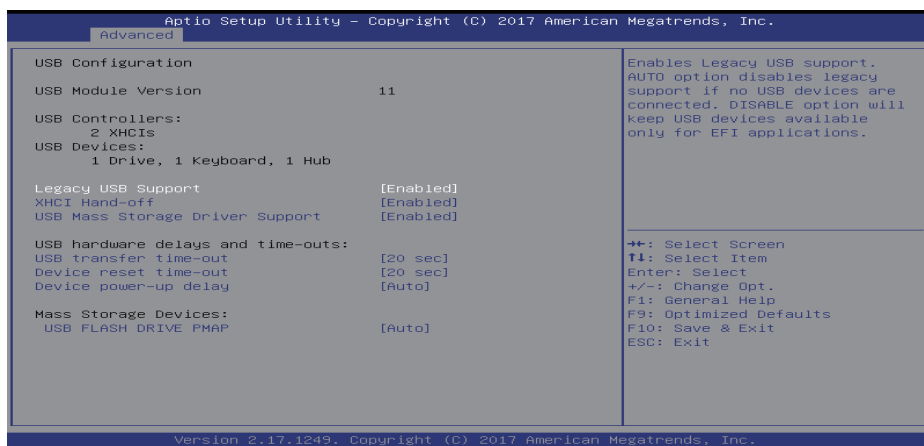

Legacy USB Support

This item determines if the BIOS should provide legacy support for USB devices like the keyboard, mouse, and USB drive. This is a useful feature when using such USB devices with operating systems that do not natively support USB (e.g. Microsoft DOS or Windows NT).

Options: Enabled (Default) / Disabled / Auto

XHCI Hand-Off

This is a workaround for Oses without XHCI hand-off support. The XHCI ownership change should be claimed by XHCI driver.

Options: Enabled (Default) / Disabled

USB Mass Storage Driver Support

The item allows you to enable or disable USB Mass Storage Driver Support.

Options: Enabled (Default) / Disabled

USB transfer time-out

The time-out value for Control, Bulk, and Interrupt transfers.

Options: 20 sec (Default) / 1 sec / 5 sec / 10 sec

Device reset time-out

The item allows you to set USB mass storage device Start Unit command time-out.

Options: 20 sec (Default) / 10 sec / 30 sec / 40 sec

Device power-up delay

“Auto” uses default value: for a Root port it is 100ms, for a Hub port the delay is taken from Hub descriptor.

Options: Auto (Default) / Manual

Device power-up delay in seconds

Delay range is 1 ~ 40 seconds, in one second increments.

Options: 5 (Default)

3.3 Chipset Menu

This section describes configuring the PCI bus system. PCI, or Personal Computer Interconnect, is a system which allows I/O devices to operate at speeds nearing the speed of the CPU itself uses when communicating with its own special components.

Note

» Beware of that setting inappropriate values in items of this menu may cause system to malfunction.

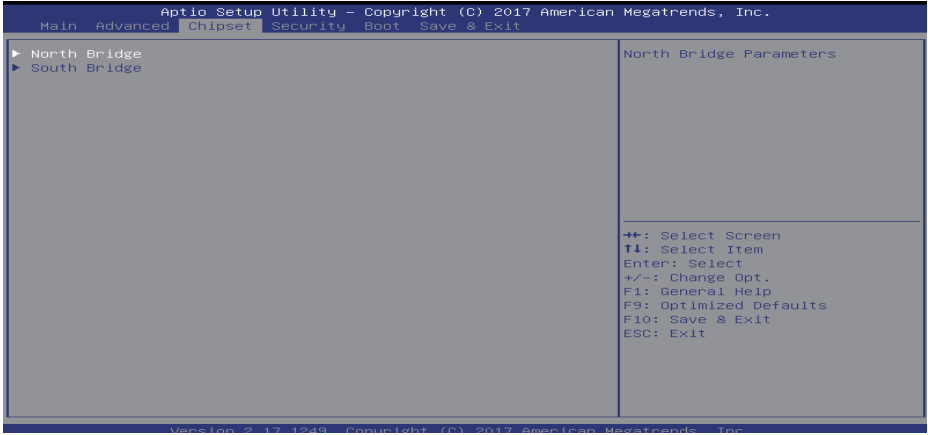

North Bridge

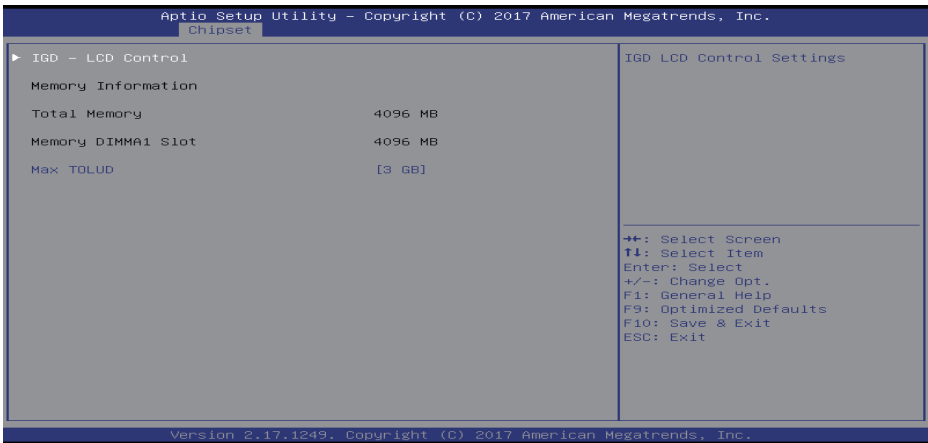

IGD - LCD Control

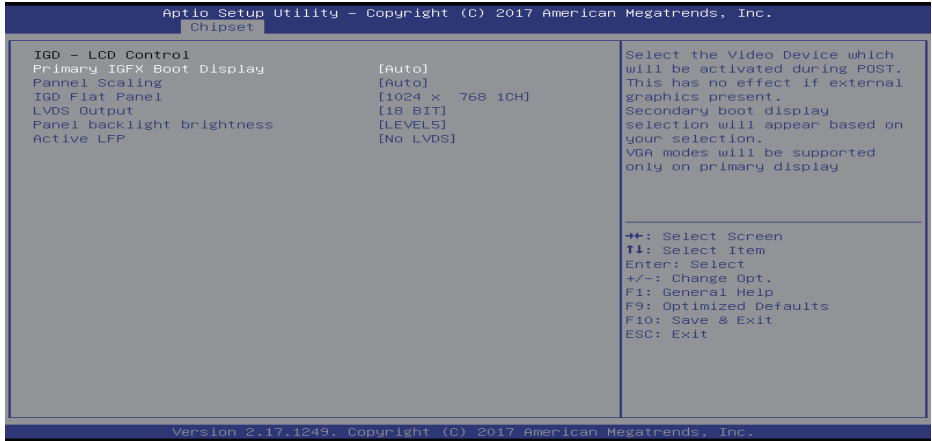

Primary IGFX Boot Display

This item allows you to select the Video Device which will be activated during POST. This has no effect if external graphics present. Secondary boot display selection will appear based on your selection. VGA modes will be supported only on primary display.

Options: Auto (Default) / LVDS / D-SUB / HDMI

Panel Scaling

This item select the LCD panel scaling option used by Internal Graphics Device.

Options: Auto (Default) / Centering / Stretching

IGD Flat Panel

This item IGD Flat Panel options.

Options: 1024 x 768 1CH (Default) / 800 x 600 1CH / 1280 x 800 1CH / 1280 x 1024 2CH / 1366 x 768 1CH / 1440 x 900 2CH / 1600 x 900 2CH / 1600 x 1200 2CH / 1920 x 1080 2CH / 1920 x 1200 2CH

LVDS Output

This item allows you to select LVDS Output is 18 or 24 bit.

Options: 18 BIT (Default) / 24 BIT

Panel backlight brightness

This item allows you to select LVDS Panel backlight brightness.

Options: LEVEL5 (Default) / LEVEL1 / LEVEL2 / LEVEL3 / LEVEL4

Active LFP

This item allow you to select the Active LFP Configuration. No LVDS: VBIOS does not enable LVDS. Int-LVDS: VBIOS enables LVDS driver by Integrated encoder.

Options: No LVDS (Default) / Int-LVDS

Max TOLUD

This item sets maximum value of TOLUD.

Options: 3G (Default)

South Bridge

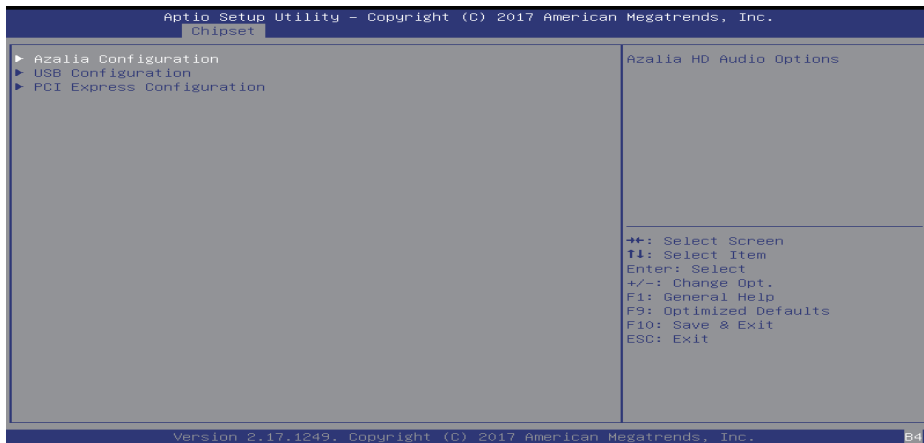

Azalia Configuration

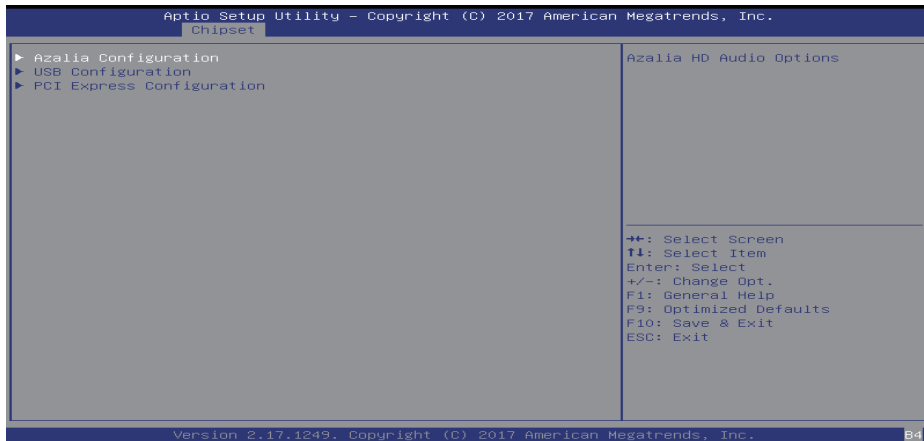

Audio Controller

This item control detection of the Azalia device. Disabled = Azalia will be unconditionally disabled. Enabled = Azalia will be unconditionally Enabled.

Options: Enabled (Default) / Disabled

Azalia HDMI Codec

This item enabled or disabled internal HDMO codec for Azalia.

Options: Enabled (Default) / Disabled

Audio AMP output

This item selects Audio AMP output dB value.

Options: 11dB (Default) / 14dB / 19dB / 25dB

USB Configuration

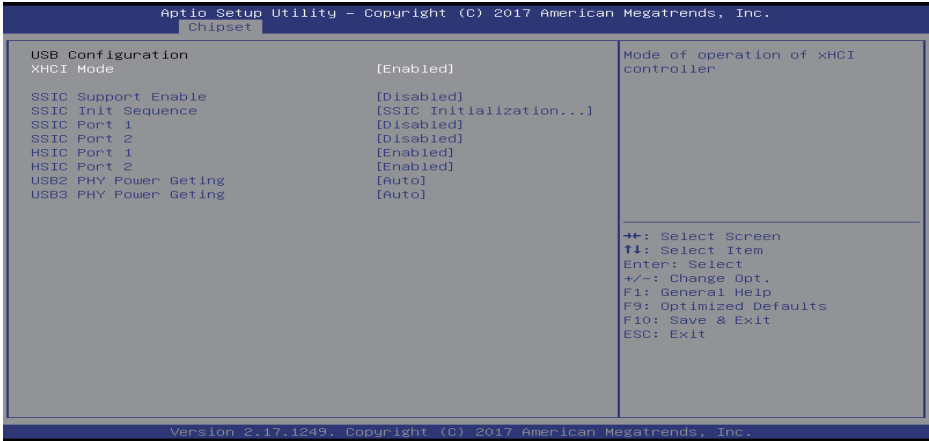

XHCI Mode

The item enabled or disabled mode of operation of xHCI controller.

Options: Enabled (Default) / Disabled

SSIC Support Enable

The item enable or disable SSIC Support.

Options: Disabled (Default) / Enabled

SSIC Init Sequence

The item selects SSIC Initialization Sequence 1 - Windows, SSIC Initialization Sequence 2 - Android.

Options: SSIC Initialization Sequence 1 (Default) / SSIC Initialization Sequence 2

SSIC Port 1/2

The item enable or disable SSIC Port 1/2.

Options: Disabled (Default) / Enabled

HSIC Port 1/2

The item enable or disable HSIC Port 1/2.

Options: Enabled (Default) / Disabled

USB2/3 PHY Power Gating

The item configure USB2/3 PHY Power Gating.

Options: Auto (Default) / Enabled / Disabled

PCI Express Configuration

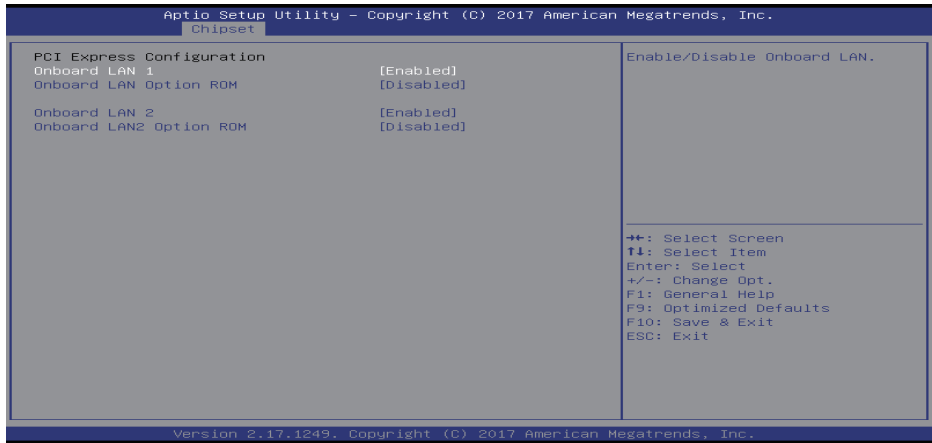

Onboard LAN1

This item enabled or disabled Onboard PCIE LAN.

Options: Enabled (Default) / Disabled

Onboard LAN Option ROM

This item enabled or disabled Onboard LAN Option ROM.

Options: Disabled (Default) / Enabled

Onboard LAN2

This item enabled or disabled Onboard LAN.

Options: Enabled (Default) / Disabled

Onboard LAN2 Option ROM

This item enabled or disabled Onboard LAN2 Option ROM.

Options: Disabled (Default) / Enabled

3.4 Security Menu

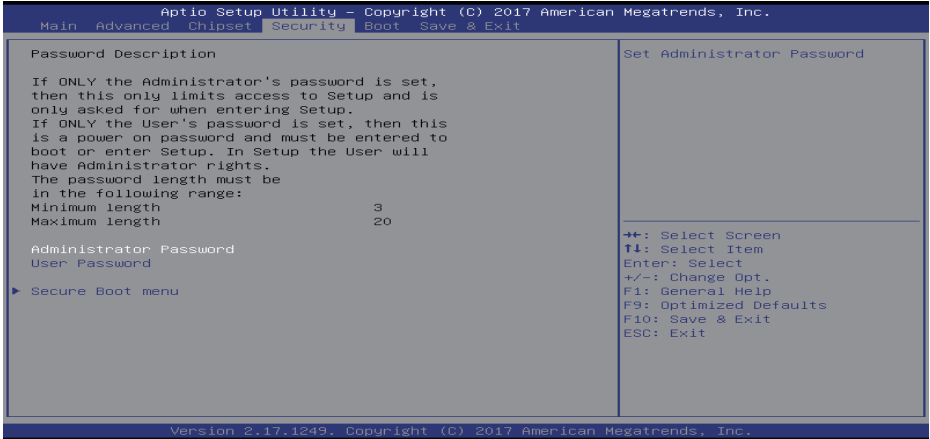

Administrator Password

This item sets Administrator Password.

User Password

This item sets User Password.

Secure Boot menu

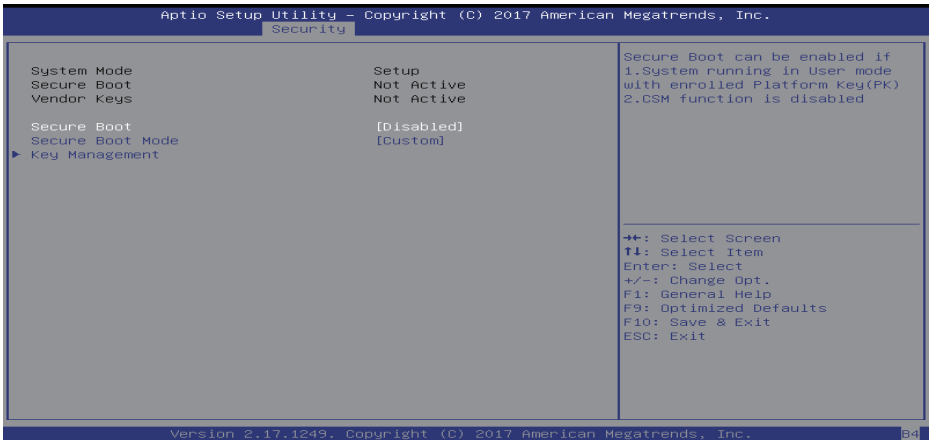

Secure Boot

Secure Boot can be enabled if 1. System running in user mode with enrolled Platform Key(PK)
2. CSM function is disabled.

Options: Disable (Default) / Enabled

» *Note: The following items appear only when you set the Secure Boot Mode function to [Custom]*

Key Management

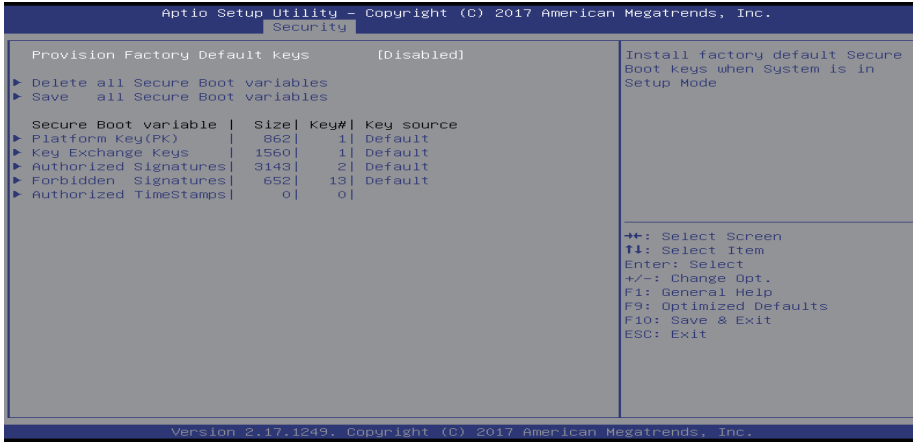

Provision Factory Default Keys

This item allows you to install factory default secure Boot keys when the system is in setup mode.

Options: Enabled (Default) / Disabled

Enroll all Factory Default Keys

This item Force System to user mode - install all Factory Default keys (PK, KEK, db, dbt, dbx). Change takes effect after reboot.

Save all Secure Boot variables

This item save NVRAM content of all Secure Boot variables to the files (EFI_SIGNATURE_LIST data format) in root folder on a target file system device.

Platform Key (PK)

Delete PK – Allows you to delete the PK file from your system.

Set new PK – Allows you set new PK file.

Key Exchange Keys (KEK)

Delete KEK – Allows you to delete the KEK file from your system.

Set new KEK – Allows you set new KEK file.

Append Var to KEK – Allows you append Var to KEK.

Authorized Signature (DB)

Delete DB – Allows you to delete the DB file from your system.

Set new DB – Allows you set new DB file.

Append Var to DB – Allows you append Var to DB.

Forbidden Signatures (DBX)

Delete DBX – Allows you to delete the DBX file from your system.

Set new DBX – Allows you set new DBX file.

Append Var to DBX – Allows you append Var to DBX.

Authorized Timestamps Database (DBT)

Set new DBT – Allows you set new DBT file.

Append Var to DBT – Allows you append Var to DBT.

3.5 Boot Menu

This menu allows you to setup the system boot options.

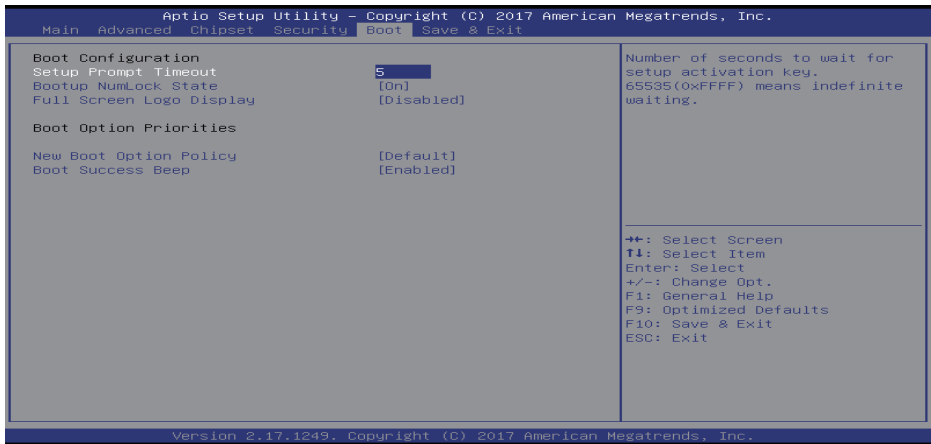

Setup Prompt Timeout

This item allows you to set number of seconds to wait for setup activation key.

Options: 5 (Default)

Bootup NumLock State

This item allows you to select the keyboard NumLock state.

Options: On (Default) / Off

Full Screen Logo Display

This item enabled or disabled Full Screen Logo Show function.

Options: Disabled (Default) / Enabled

New Boot Option Policy

This item allows you to control the placement of newly detected UEFI boot options.

Options: Default (Default) / Place First / Place Last

Boot Success Beep

When this item is set to Enabled, BIOS will let user know boot success with beep.

Options: Enabled (Default) / Disabled

3.6 Exit Menu

This menu allows you to load the optimal default settings, and save or discard the changes to the BIOS items.



Save Changes and Reset

Reset the system after saving the changes.

Discard Changes and Exit

Abandon all changes made during the current session and exit setup.

Restore Defaults

This selection allows you to reload the BIOS when problem occurs during system booting sequence. These configurations are factory settings optimized for this system.